

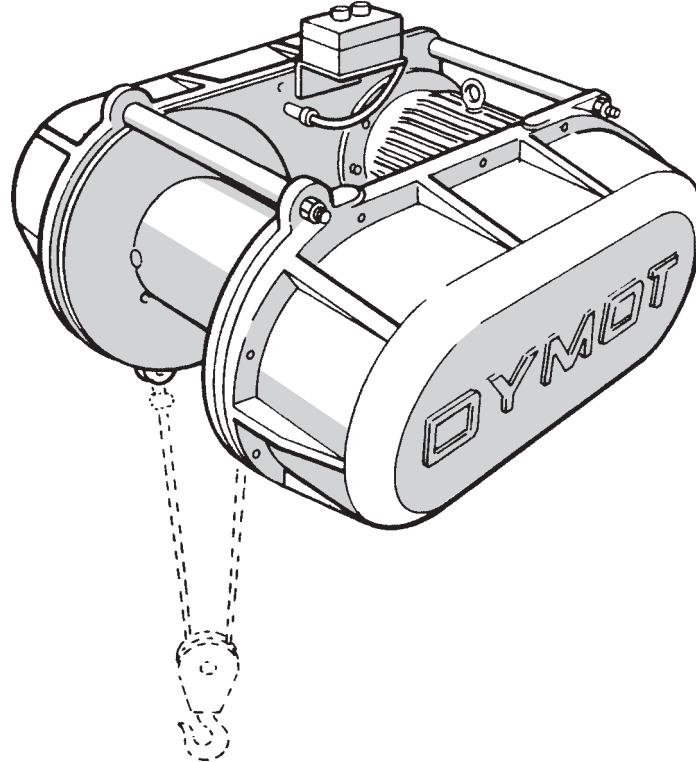

ELECTRIC WINCH 1 TON CAPACITY - MODEL DSB 2,2



GENERAL INFORMATION

These winches can only be used in the horizontal mounting position as shown or inverted, in this way the oil level in the gearbox is maintained.

This winch can lift 2 tons using 2 falls of rope, this configuration will halve the lifting speed.

The push button controls can be removed from the winch and mounted remotely. To do this the cable would have to be extended.

FEATURES

- Reliable, robust and long lasting.
- Compact design, economic and versatile.
- Estimated mass 225 kg.
- Failsafe electro-magnetic brake/motor shaft.
- Line speed 11 m/min.
- Line pull 1000 kg.
- Motor power 2.2 kW. Available in 380V and 525V - 3 phase.

SPECIFICATIONS

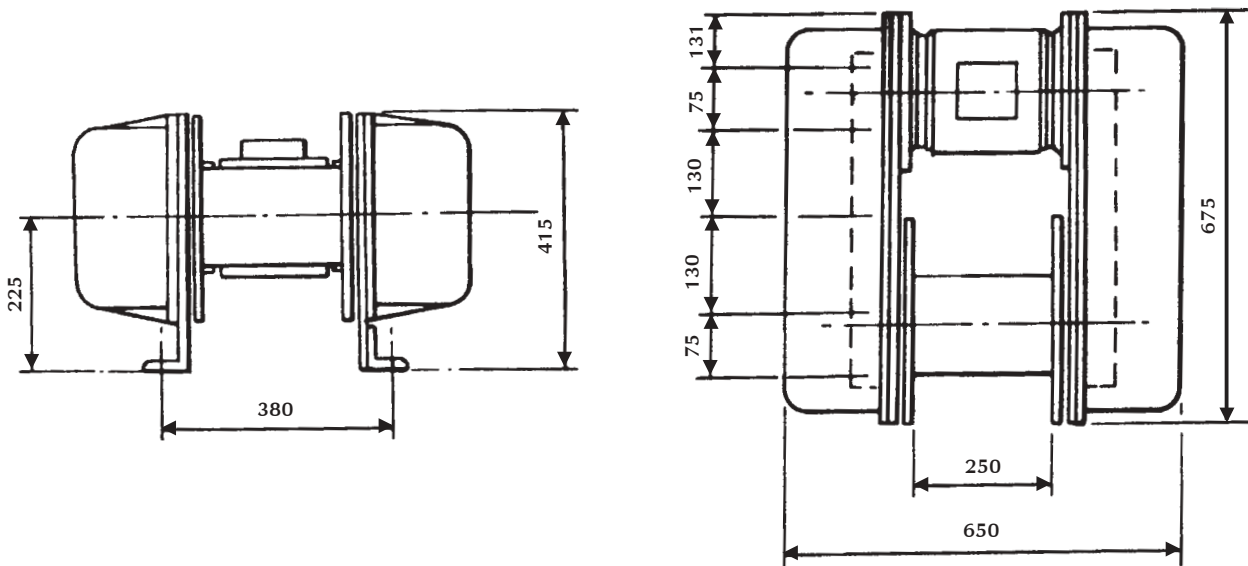

MODEL DSB 2,2

Drum Capacity 10 Ø Wire Rope 125 metres
Maximum Working Length = 90 metres

Drum Capacity 8 Ø Wire Rope 220 metres
Maximum Working Length = 160 metres

Drum Flange Diameter 330mm

Drum Diameter 150mm

The rope can be wound onto the drum either overlay or underlay but care must be taken to ensure that it does not touch the tie rods or the motor when in operation with the drum full or empty.

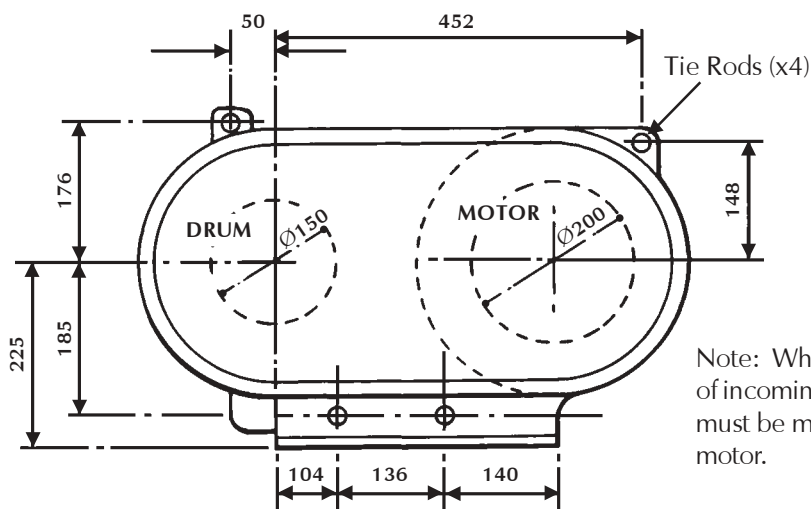

Note: When planning position of incoming rope allowance must be made for tie rods and motor.

* Specification is subject to change without prior notice



DYMOT ENGINEERING COMPANY (Pty) Ltd
11 Derrick Road, Spartan, Kempton Park, S.A. ● P O Box 404,
Edenvale, 1610 ● Tel: +27 11 970-1920 ● Fax: +27 11 970-1979
Website: www.dymot.co.za ● E-Mail: sales@dymot.co.za