

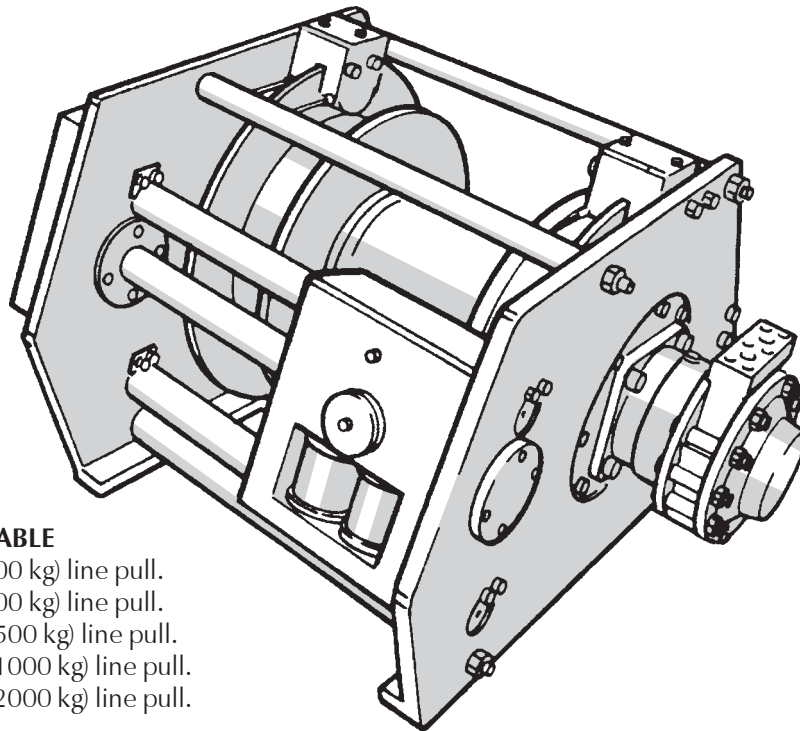

HYDRAULIC RECOVERY WINCHES

Models HE15, HE45, HE100, HE200, HE400
(MODEL NUMBER DENOTES TEST LOAD IN kN)



WINCH SIZES AVAILABLE

- Model HE15 (kN) (1000 kg) line pull.
- Model HE45 (kN) (3000 kg) line pull.
- Model HE100 (kN) (5500 kg) line pull.
- Model HE200 (kN) (11000 kg) line pull.
- Model HE400 (kN) (22000 kg) line pull.

GENERAL AND TECHNICAL INFORMATION

These constant torque winches can be used wherever hydraulic power is available and are ideally suited to mounting in light and heavy vehicles. The speed can be infinitely varied by using a variable displacement power pack. One of the main features of using hydraulic power is the efficient working overload protection. The operating position is easily placed in or around the vehicles. Winch mountings can be custom fabricated to meet your specific needs. Custom built power packs can be supplied on request.

USES

- All areas where power must be generated.
- All spheres of VEHICLE RECOVERY including military vehicles and armoured vehicles.
- Conveyor tensioning.
- Raising and lowering of goods or product in sample shafts.
- Erection on remote area sites.

FEATURES

- Greater versatility.
- Safer operation.
- More flexible installation.

NOTE: Even though we manufacture a wide range of standard winches we will manufacture specials to suit customers requirements.

SPECIFICATIONS

Rope pull & speed calculated on first layer of rope

Mountings custom made to suit individual requirements

Automatic internal brake

Free spooling gear for quick pull out of rope

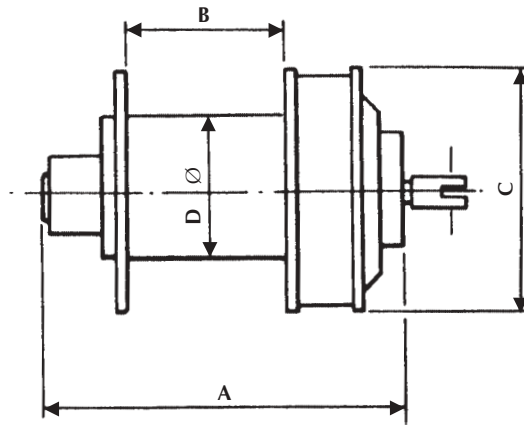

MODEL HE 400

220 kN LINE PULL WINCH

A	1160	Power Required 50 kW (For Test Load)	Hydraulic Pressure 19 MPa Hydraulic Flow 160 ℓ/min.
B	698	Rope Speed 4 & 16 m/min.	
C	740	Rope Size min. 32Ø 6 x 36 IWRC Construction	
D	450	Drum Capacity 130 m	

MODEL HE 200

110 kN LINE PULL WINCH

A	1092	Power Required 32 kW (For Test Load)	Hydraulic Pressure 22 MPa Hydraulic Flow 85 ℓ/min.
B	433	Rope Speed 6,6 m/min.	
C	625	Rope Size min. 26Ø 6 x 36 IWRC Construction	
D	364	Drum Capacity 110 m	

MODEL HE 100

55 kN LINE PULL WINCH

A	658	Power Required 28 kW (For Test Load)	Hydraulic Pressure 18 MPa Hydraulic Flow 95 ℓ/min.
B	300	Rope Speed 16 m/min.	
C	450	Rope Size min. 20Ø 6 x 36 IWRC Construction	
D	260	Drum Capacity 80 m	

MODEL HE 45

30 kN LINE PULL WINCH

A	650	Power Required 10 kW (For Test Load)	Hydraulic Pressure 11 MPa Hydraulic Flow 55 ℓ/min. (No free Spool)
B	220	Rope Speed 12 m/min.	
C	400	Rope Size min. 13Ø 6 x 36 IWRC Construction	
D	236	Drum Capacity 60 m	

MODEL HE 15

10 kN LINE PULL WINCH

A	675	Power Required 20 kW (For Test Load)	Hydraulic Pressure 16 MPa Hydraulic Flow 75 ℓ/min. (No free Spool)
B	300	Rope Speed 24 m/min.	
C	438	Rope Size min. 10Ø 6 x 36 IWRC Construction	
D	250	Drum Capacity 250 m	

* Specification is subject to change without prior notice



DYMOT ENGINEERING COMPANY (Pty) Ltd
 11 Derrick Road, Spartan, Kempton Park, S.A. ● P O Box 404,
 Edenvale, 1610 ● Tel: +27 11 970-1920 ● Fax: +27 11 970-1979
 Website: www.dymot.co.za ● E-Mail: sales@dymot.co.za