

Bearing Lubricator
Laer Smeringsapparaat

GENERAL & TECHNICAL

The Dymot D350 grease pump is a portable foot operated pump, cast in aluminium. Standing 400mm long x 400mm high the pump weighs 12kg dry and has a capacity of 5kg of grease. It delivers 2,5cm³ per stroke at 350 bars pressure. Both hands are always free for the lubrication application. Supplied with 2m or more of high pressure hose and required fittings.

FEATURES

- Efficient Greasing
- Reduces Costly Breakdowns & Downtime
- This Pump is Cheaper than Spare Parts
- 100% S.A. Manufacture
- Optional Extra - Bearing Lubricator

ALGEMEEN & TEGNIES

Die Dymot D350 Ghriespomp is 'n draagbare voetpomp wat die hande vry laat om smering te vergemaklik en is in aluminium vervaardig waarvan die droë gewig 12kg is. Die pomp is 400mm lank x 400mm hoog en het 'n kapasiteit van 5kg ghries en lewer 2,5 cm³ per slag teen 'n drukking van 350 bar. Standaard toerusting sluit 2m of meer hoë druk buigbare pyp met die nodige koppelings.

FEATURES

- Deeglike Smering
- Verminder Duur Teespoedkoste en Bespaar Tyd
- Hierdie Pomp is Goedkoper as Spaarparte
- 100% S.A. Vervaardig
- Opsionale Ekstras - Laer Smeringsapparaat



BEARING LUBRICATOR

for Bearings up to 170mm O.D.

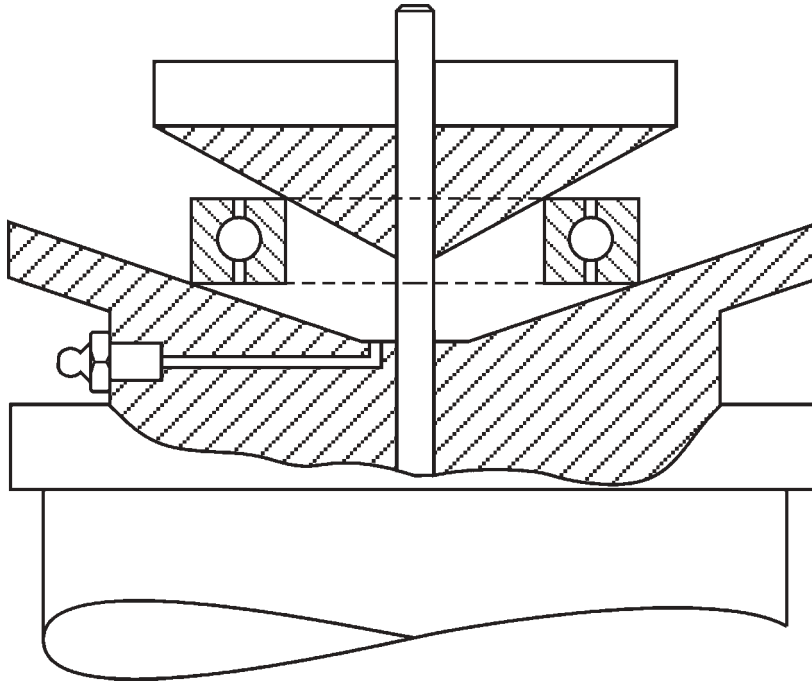

Bearing Lubricators which can be bench mounted or used as lids, are available. To pack a bearing with grease the male cone is removed and the bearing is placed centrally on the female cone. Tightening of the male cone seals the bearing in position. A grease nipple is provided on the side of the female cone for connecting the pump hose. Grease is pumped evenly through the bearing by operating the pump.

'n Laer smeringsapparaat wat op die werksbank gemonteer kan word is ook beskikbaar. Om 'n laer te vul met ghries, moet die manlike kegelvorm verwyder word, en die laer gelyk geplaas word op die vroulike kegelvorm. Die manlike kegelvorm seël die laer in posisie. 'n Smeerpunt word voorsien aan die kant van die vroulike kegel vir koppeling met die pompslang. Sodra met die pomp gewerk word, sal die ghreis eweredig deur die laer gevoer word.



DYMOT ENGINEERING COMPANY (Pty) Ltd
11 Derrick Road, Spartan, Kempton Park, S.A. ● P O Box 404,
Edenvale, 1610 ● Tel: +27 11 970-1920 ● Fax: +27 11 970-1979
Website: www.dymot.co.za ● E-Mail: sales@dymot.co.za